

Motorized slide one or two axis, light and compact

1 axe: 1,05 Kg

2 axis: 2,10 Kg

- useful stroke 40 mm (40x40 with 2 axis)
- max load out 50 mm: 5 Kg
- motor 24 Vdc, with encoder
- max speed 2000 mm/min
- protection bellows
- ball bearing screw with linear guide

Possibility to use this slide with all the machine of Carpano range: seamtracker, oscillator, AVC, manual slides, CNC controls..

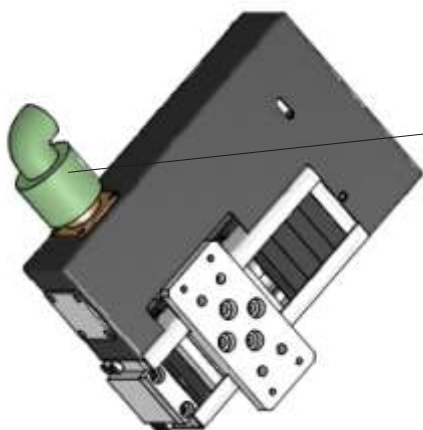

standard model with
cable connection on
long side

on demand with
connector on short
side

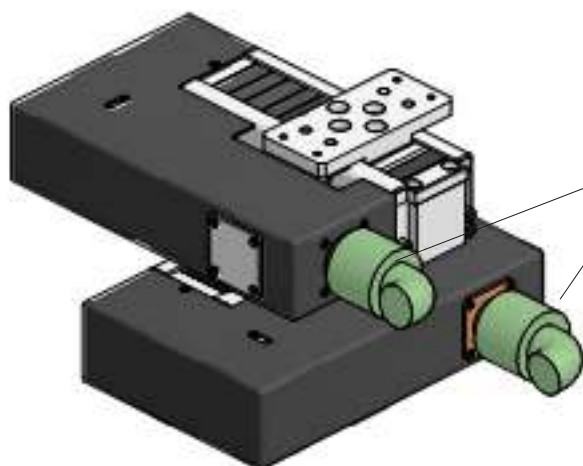
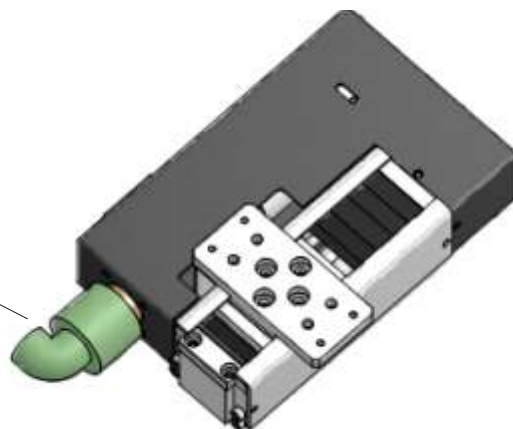

2 axis model, in this drawing the
connectors are on the top side

some work exemple



CARPANO
EQUIPMENT

as seamtracker on the Squirrel

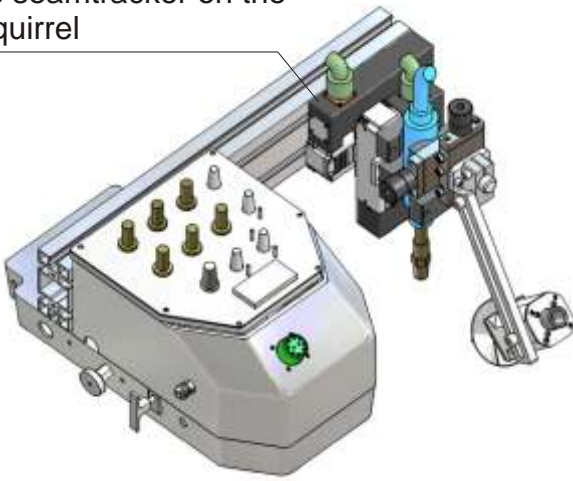

as oscillator on the W-track

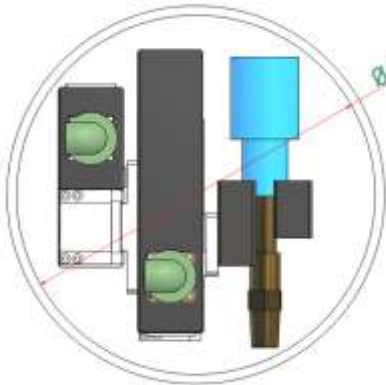
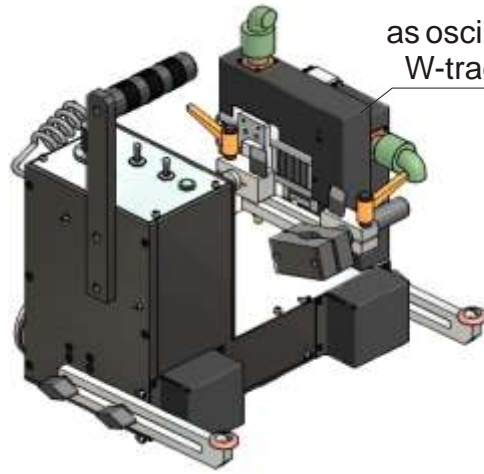

to correct the torch position inside small pipes, in circumferential position or longitudinal. please note also as in the 2 exemples change also the connectors position

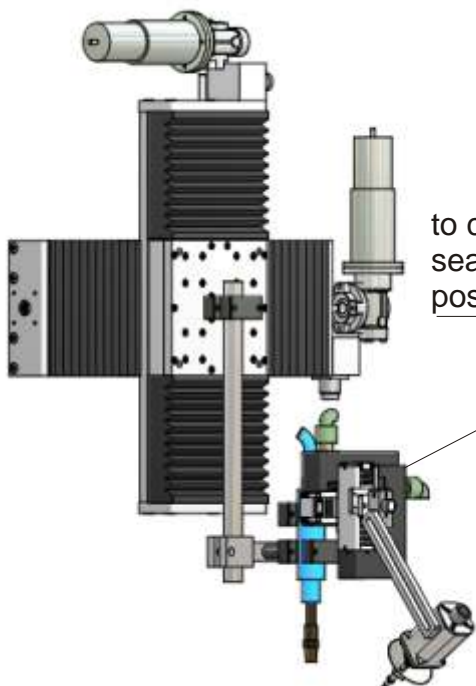
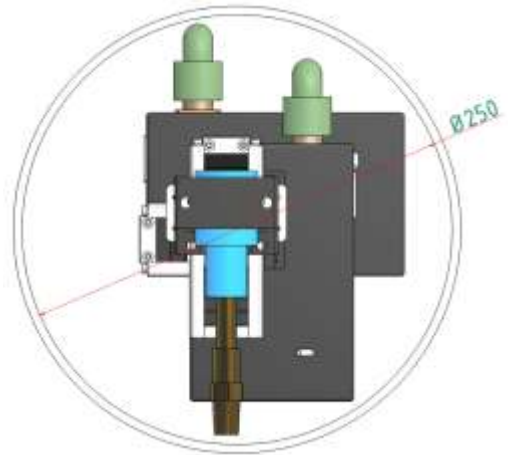

to change the seamtracker probe position on a IGMD.

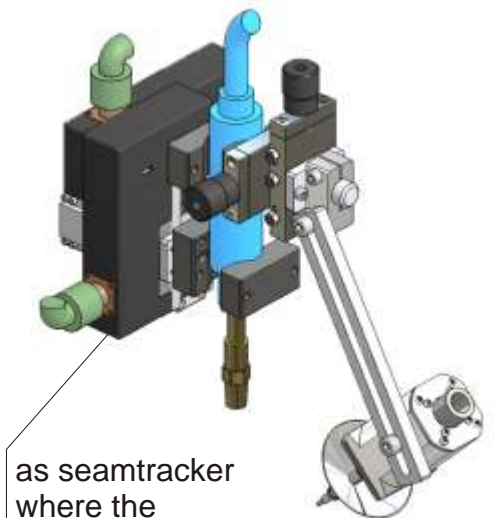

as seamtracker where the customer need a small cross slide

Dimensions - MM Micro 40-1



CARPANO
EQUIPMENT

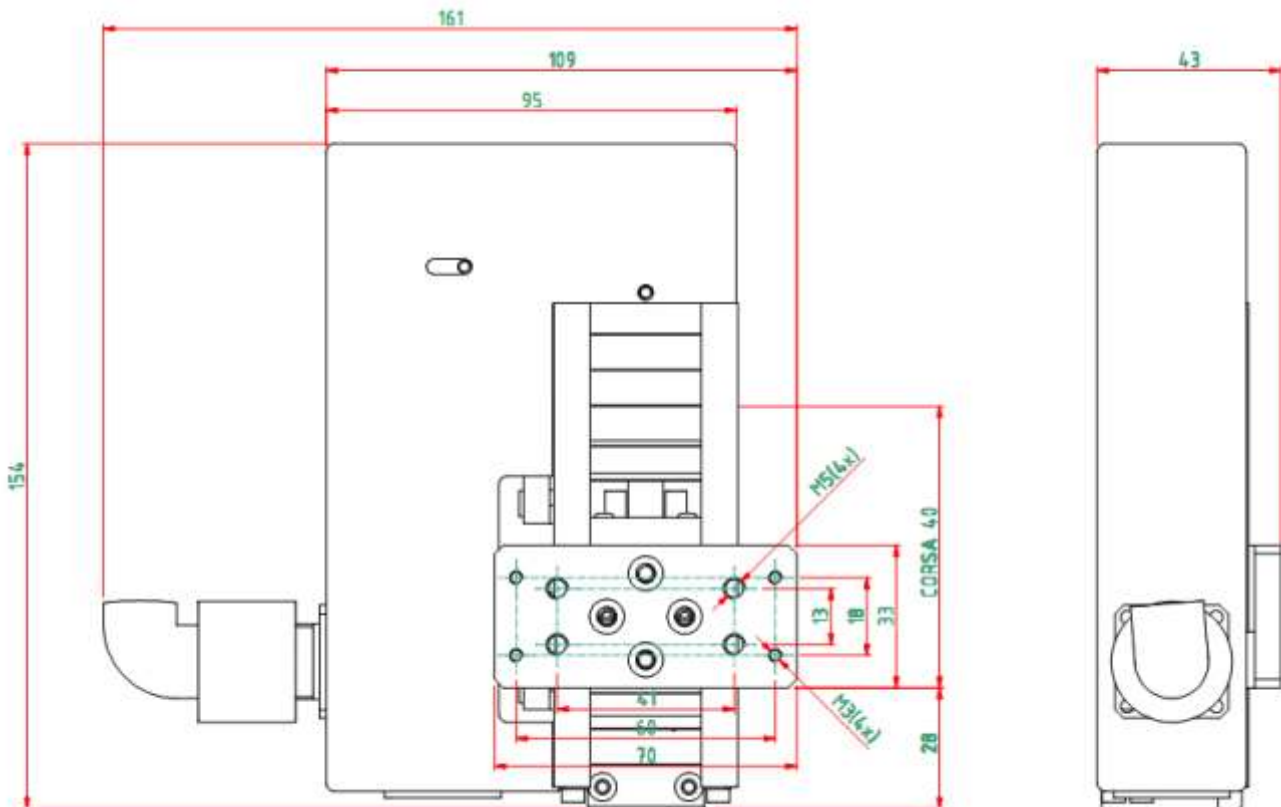
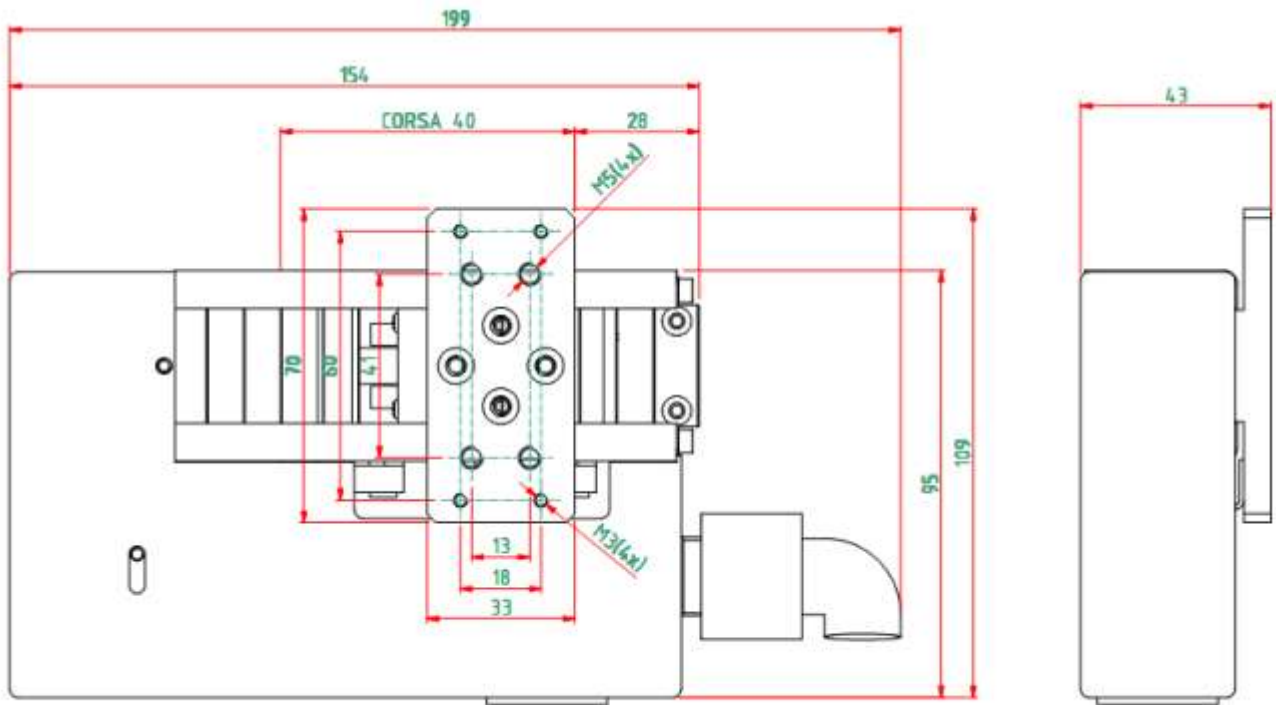

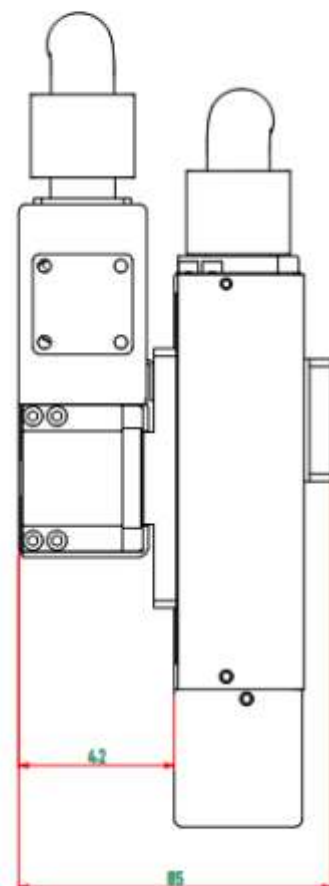
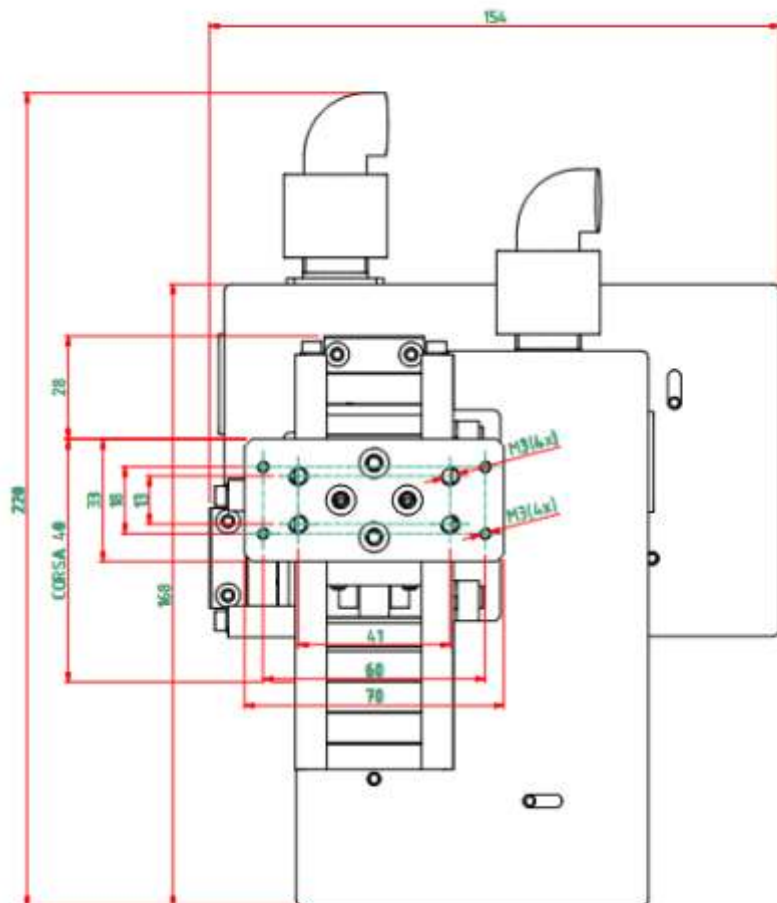

CARPANO
EQUIPMENT

WELDING AUTOMATION

CARPANO EQUIPMENT Srl
via Cà dell'Orbo sud, 10
40055 Castenaso fraz.Villanova
Bologna - Italy
tel. +39 051 6053215 - fax +39 051 6053218
info@carpano.it
www.carpano.it