



| ENG

BY2-RB

2 Ton self-aligning rotators

carpano.it

BY2-RB

2 Ton self-aligning rotators

Due to the multi-wheel support, they are particularly suitable for use on pieces with small thickness, as they better compensate for the deformation effect due to weight.



We reserve the right of modifying the technical features of machinery as stated herein and we do not respond for any printing mistake.

All rights reserved. Text and images can be reproduced only after our written authorization.

- The updated version is the one in our web site



OBY2-RB code includes:

- 01 – OBY2-RB-E1F drive unit
- 02 – OBY2-RB-NF idle unit
- 03 – Rollo1-CD remote control with 5m cable (other on request)

General features:

- Welded and painted carpentry
- Wheelbase adjustment by holes and pins
- Servo-ventilated AC gearmotor controlled by inverter, transmission by traction on two tilting wheels
- Wheels with steel hubs, tyred with rubber (other on request)

Functions and controls



1. Feeding cable 230V single-phase
2. Remote control connection
3. Speed display in cm/min
4. Torch contact



Rollo1-CD

Rollo1-CD consists in a Start/Stop double foot-switch with a small control box on its top

1. Rollo1-CD with 5m cable
2. Start pedal (4T)
3. Stop pedal
4. Emergency
5. 10 turn potentiometer for speed adjustment
6. Regulated/mas speed switch
7. CW/CCW rotation switch
8. Weld ON/OFF switch

Instead of Rollo1-CD it is possible to choose a remote control pendant, most suitable to control the machine from the inner side of a pipe or from a scaffold.

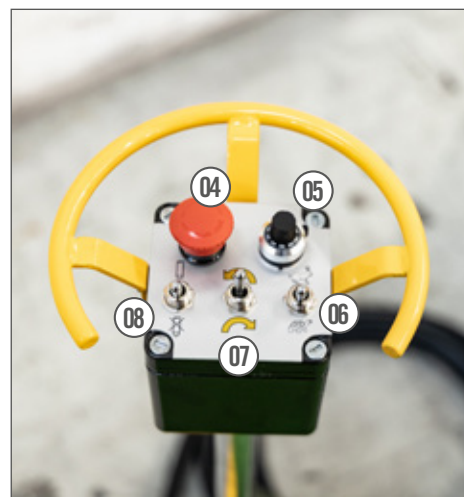
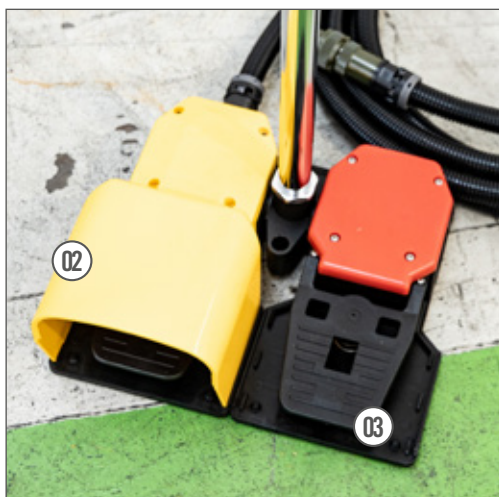

OBY2-RB – Technical data

Unit weight capacity	1000kg	Feeding	230V, single-phase
Wheelbase adjustment	by holes and pins	Power installed	0.18kVA
Wheels	Ø200x80 mm tyred with rubber	Speed	100-1000 mm/min
Min/max workpiece diameter	500-3000 mm under full load 200-500 mm under half load	Drive unit weight	130 kg
		Idle unit weight	170 kg

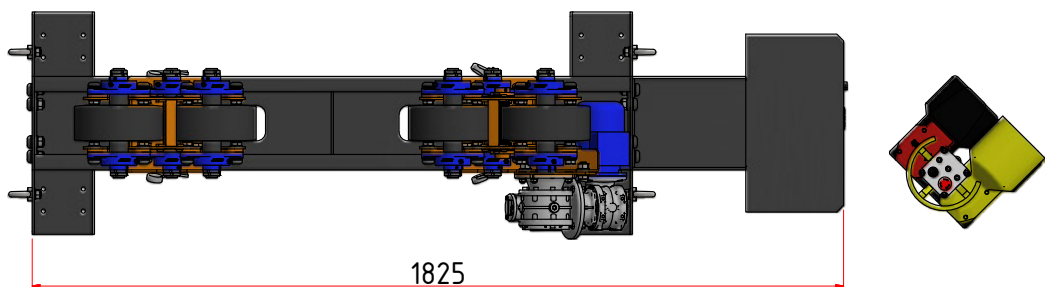
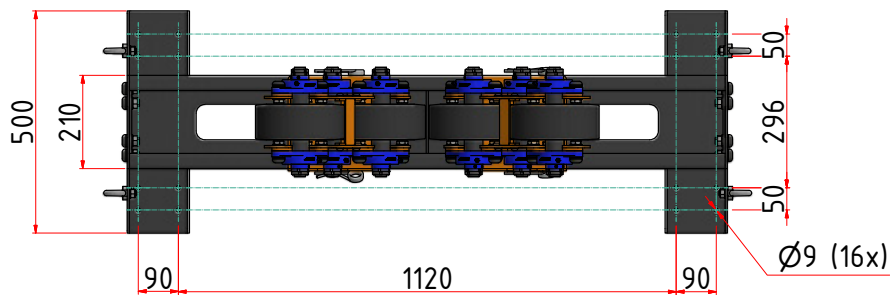
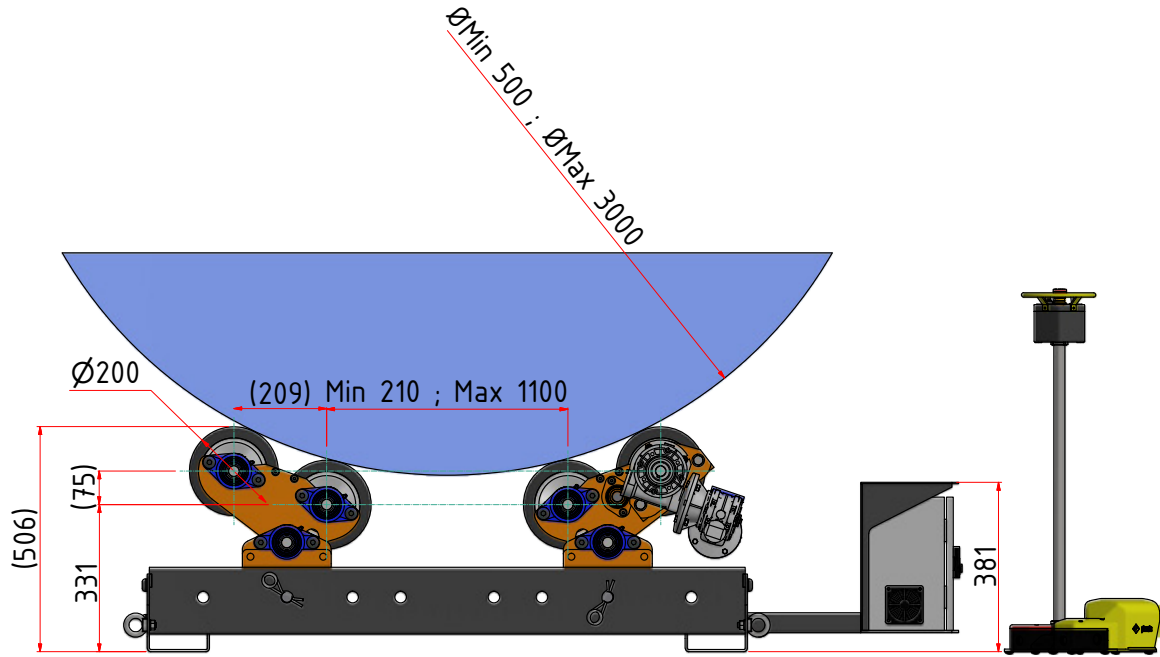

■ **OBY2-RB with OBY.C2 idle undercarriages for traversing on rails**



4 pcs one-wheel groups are installed on each unit

- 2 groups provided with straight-profile wheel, one of which with handbrake
- 2 groups provided with double-flanged wheel, one of which with handbrake

Overall code of the undercarriages for each unit: **OBY.C2**

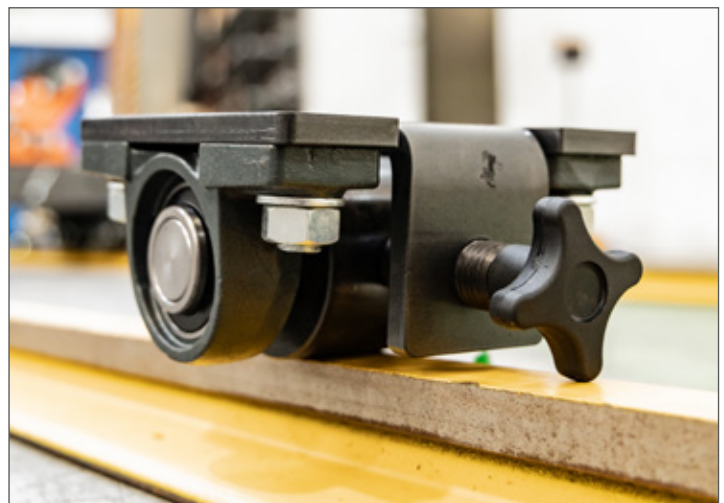

Dimensions of OBY2-RB with OBY.C2 undercarriages

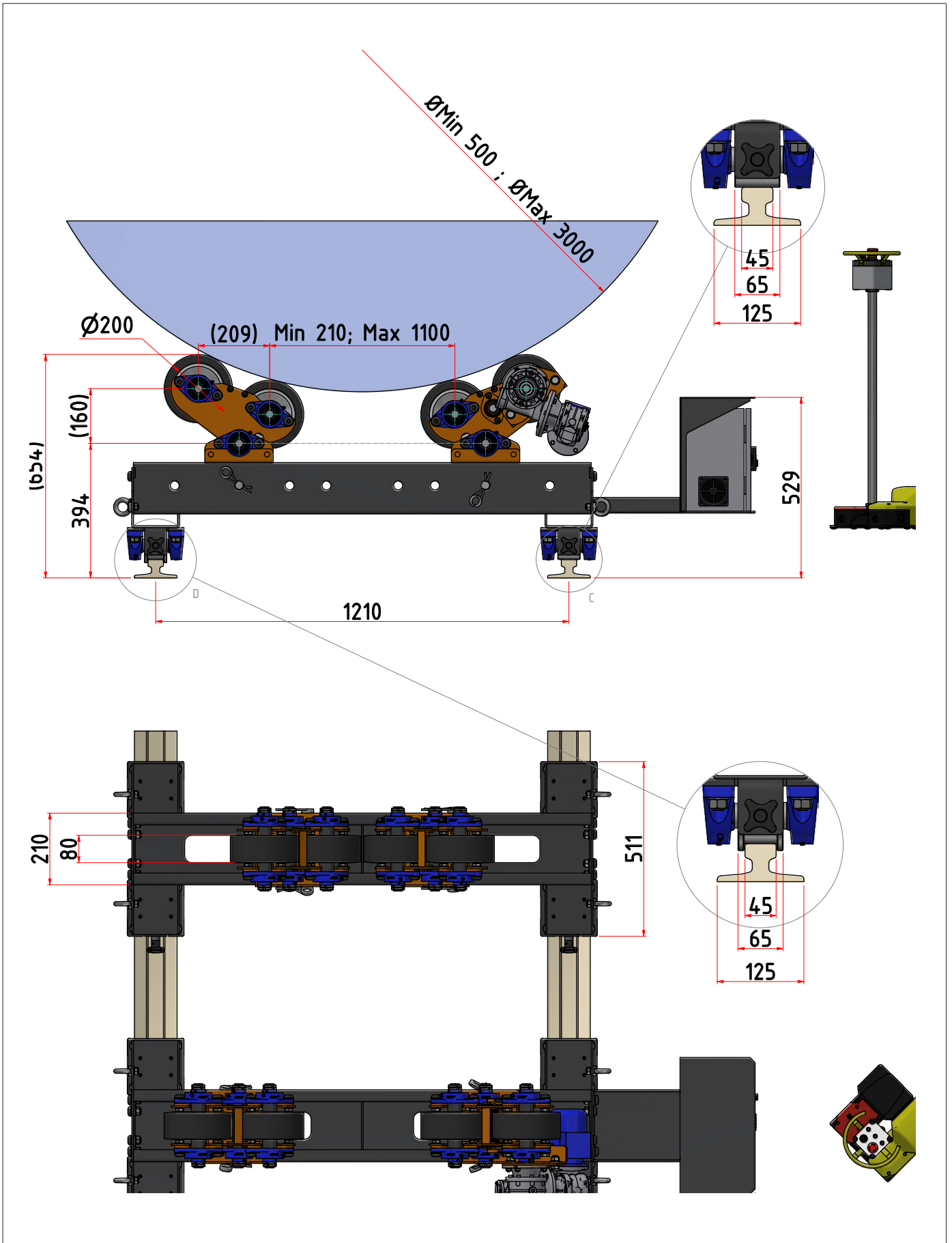

■ OBY2-RB with OBY.C2 idle undercarriages for traversing on rails

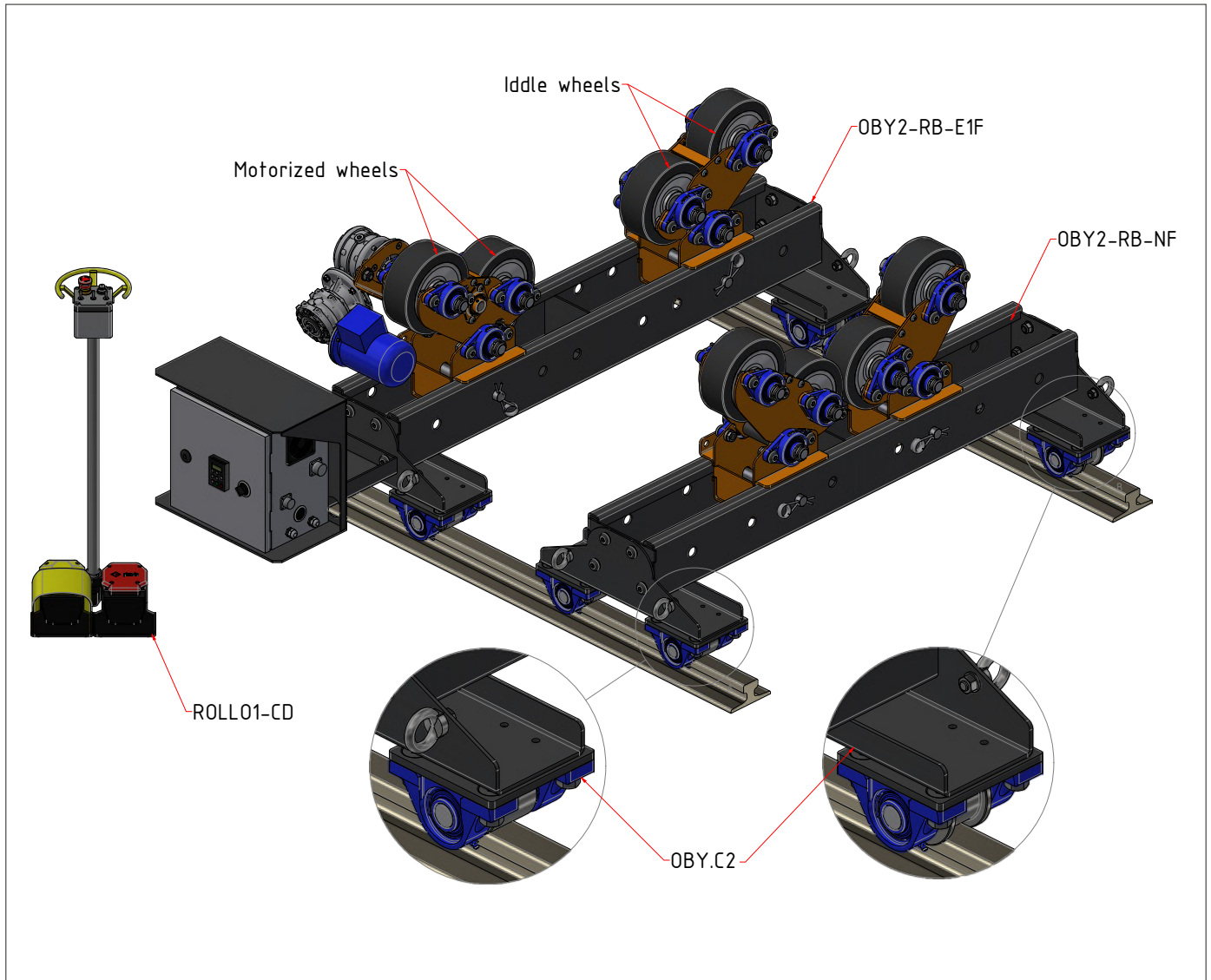

Codes for ordering individual parts

1. OBY2-RB-E1F: drive unit, includes the electric cabinet and the remote control Rollo1-CD
2. OBY2-RB-NF: idle unit
3. OBY.C2: kit of undercarriages for one unit (drive or idler)



1. Wheels positioning diagram, with \varnothing min and \varnothing max allowed

Model: OBY2-RB

Capacity: 1 Ton per unit

\varnothing min – \varnothing max: 500 mm – 3000 mm

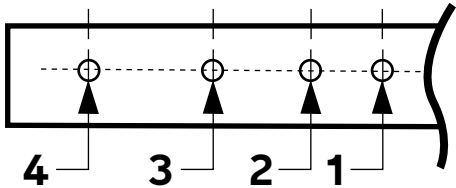
	-	\varnothing min	\varnothing max
	1	-	-
	2	500	1100
	3	1100	2000
	4	2000	3000





GENERAL SUPPLY CONDITIONS

1. SUPPLY OBLIGATION ARRANGEMENT

The following general terms of business are always to be considered applicable to every order made by the buyer. Therefore, any supply clause written by the buyer on his orders or any other document given to the seller, which may result to be conflicting with the present general conditions, will be considered not written. The buyer has to forward the orders to the seller in writing. The seller reserves the authority to accept telephone and verbal orders. The order is to be considered executed when the buyer receives the written acceptance of the same (order confirmation) by the vendor or, in the absence thereof, automatically 15 days after the order receipt by the seller. All offers and prices are just an indication and are not binding. Therefore the seller considers himself to be bound only to what is declared in his order confirmations.

2. TERMS FOR DELIVERY

The delivery dates indicated by the seller as well as the ones written on the buyers' orders have to be considered just as an indication and are not binding and are subject to the punctual supply by the buyer of all the specifics, to the variations due to the availability of the goods with the suppliers or to reasons of force majeure: delays in the delivery due to said availability variations are not attributable to the seller, who is not in duty bound to the compensation for damages suffered by the buyer. Reasons of force majeure have also to be considered the accidents (industrial injury, disease, etc) and any other circumstances which may cause a total or partial job reduction, as well as the lack of raw materials, troubles with transportation, etc. The seller reserves the authority to suspend the delivery of the goods if the buyer has not seen to the payment of the invoices relative to other supplies whose terms of payment are overdue. The goods are understood as being delivered for all intents and purposes to the buyer from the time they were picked up by the carrier or the buyer himself at the seller's warehouse.

3. PAYMENT AND TERMS OF PAYMENT

The payments have to be made to the seller's domicile and in accordance with the established conditions. In the event of a delay, the due amounts of money will automatically imply the charge of interests based on the official discount rate plus 5 points. In the event of a non-payment, the buyer is to be considered in default without the necessity of any formal notice by the seller. The presence of possible faults and/or defects in the products does not excuse the buyer for suspending the payment of the invoices. Should the client suspend and/or delay the payments, the seller may suspend the supplies, with the authority to consider the contract automatically terminated by rights and to demand for damages.

4. WARRANTY

CARPANO EQUIPMENT guarantees the products for a period of 24 months starting from the delivery date, for a daily work cycle of 8 hours. The warranty is intended ex works CARPANO EQUIPMENT. CARPANO EQUIPMENT guarantees the performance of its products in accordance with the instructions written in the relative manuals. For the products based on job orders, the warranty is pertaining to the specifics agreed with the client.

5. VOID WARRANTY

In case of any tampering or unauthorized intervention the warranty shall be deemed void.

6. LIABILITY FOR DAMAGE

The seller's liability is limited only to the obligations above and it's expressly agreed that the seller does not accept any liability for damages resulting from any cause connected with the use and utilization of the sold products.

CARPANO EQUIPMENT is not responsible and for no reason whatsoever may the expenses be charged for:

- Machine downtime.
- Direct or in direct damage due to the non-operation of the equipment.
- Working hours spent to solve possible problems on the equipment.

7. RESERVATION OF OWNERSHIP

Until the payment in full of any credit resulting from business relations has taken place, included any additional credit and until the payment of bills and cheques has been made, the property in the goods remains in the seller.

8. COMPETENT COURT

It's established that the court of Bologna will be the sole competent court for every dispute relative to this contract.

9. APPLICABLE LAWS

The applicable law is the Italian law.



CARPANO EQUIPMENT Srl

Via del Legatore, 7 / 40138 Bologna Italy

T. +39 051 6053215 / e-mail: info@carpano.it

carpano.it