



JUNIOR

Turn and tilt table positioner
max weight capacity 50 kg

carpano.it

JUNIOR

is a turn and tilt table positioner with max weight capacity 50 kg, it includes a START/STOP footswitch and it can be supplied equipped with a CHK-ST-125 or a GRIP200 chuck



We reserve the right of modifying the technical features of machinery as stated herein and we do not respond for any printing mistake.

All rights reserved. Text and images can be reproduced only after our written authorization.

- The updated version is the one in our web site

Turn and tilt table positioner



Including:

1. Turning and tilting table
2. START/STOP footswitch with 5m cable and rod for manual transport
3. 5m feeding cable

Available models:

JNR15 – with rotation speed variable from 1.5 to 15 rpm

JNR8 – with rotation speed variable from 0.72 to 7.2 rpm

JNR4 – with rotation speed variable from 0.39 to 3.9 rpm

Mechanical features

Capacity with table in flat position	JNR15	JNR8	JNR4
	50 kg	50 kg	50 kg
Rotation speed	1.5 <> 15 rpm	0.72<>7.2 rpm	0.39<>3.9 rpm
Rotation torque	3.5 kgm	4.6 kgm	3.5 kgm
Tilt torque	7 kgm	7 kgm	7 kgm
Tilting	0°-90°	0°-90°	0°-90°
Weight	16 kg	16 kg	16 kg
Power installed	90 W	90 W	90 W
Dimension A	386	429	429
Dimension B	488	531	531
Weight of packaging	19.5 kg	19.5 kg	19.5 kg
Packaging dimensions	51x31xH42 cm	51x31xH42 cm	51x31xH42 cm



1. Snap lever for tilt lock
2. START/STOP footswitch included into supply
Code for separate order JNR-FS

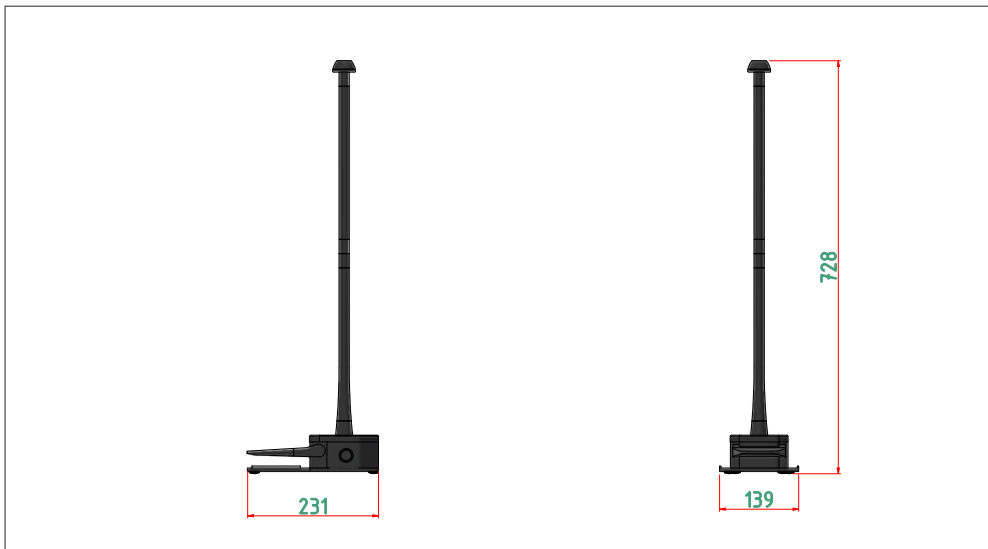

Dimensions:

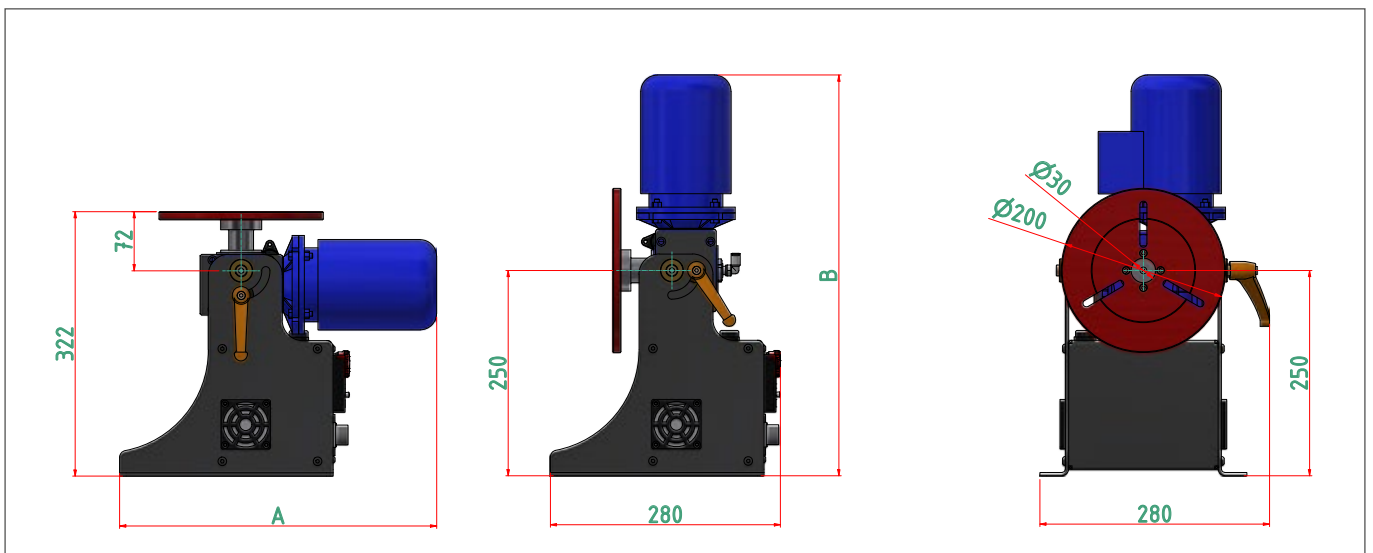

Electrical features and parts common to all three models

Feeding	230V single-phase
Power installed	90 W
Ground connection capacity	200 Amp @ 100% 300 Amp @ 60%
HF shielding	Present
Digital tachometer in rpm	Present
Emergency button	Present
10 turn potentiometer	Present
Switch for Impulsive/Continuous control from the for START/STOP footswitch	Present
CW/CCW rotation switch	Present
Max/Adjusted speed switch	Present

1. Display for monitoring rotation speed, in rpm
2. 10 turn potentiometer for speed adjustment
3. Emergency button
4. Max/Adjusted speed switch
5. CW/CCW rotation switch
6. Switch for Impulsive/Continuous control from the START/STOP footswitch
7. START/STOP footswitch connector
8. Main switch with feeding connection and fuse
9. Plug for GIFAS 70 mm² ground cable
10. Joint for gas/air outlet coaxial to the table



■ Accessories: Key-chuck / Lever-chuck



Grip 200 chuck: installed directly on table's slots, without flange.



CHK-ST-125 chuck: installed directly on table's slots, without flange

Positioner **ONE** (left) and **JUNIOR** (right) comparison.

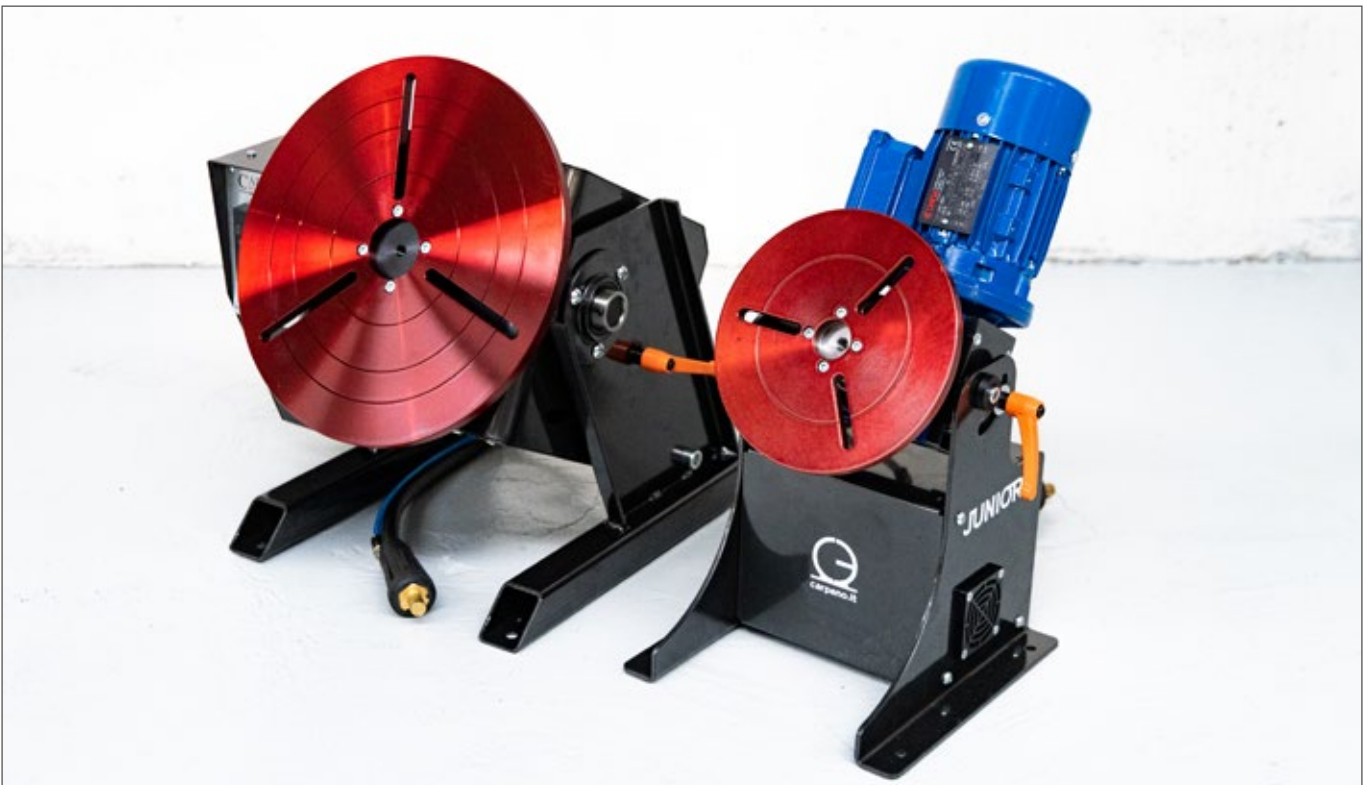



GENERAL SUPPLY CONDITIONS

1. SUPPLY OBLIGATION ARRANGEMENT

The following general terms of business are always to be considered applicable to every order made by the buyer. Therefore, any supply clause written by the buyer on his orders or any other document given to the seller, which may result to be conflicting with the present general conditions, will be considered not written. The buyer has to forward the orders to the seller in writing. The seller reserves the authority to accept telephone and verbal orders. The order is to be considered executed when the buyer receives the written acceptance of the same (order confirmation) by the vendor or, in the absence thereof, automatically 15 days after the order receipt by the seller. All offers and prices are just an indication and are not binding. Therefore the seller considers himself to be bound only to what is declared in his order confirmations.

2. TERMS FOR DELIVERY

The delivery dates indicated by the seller as well as the ones written on the buyers' orders have to be considered just as an indication and are not binding and are subject to the punctual supply by the buyer of all the specifics, to the variations due to the availability of the goods with the suppliers or to reasons of force majeure: delays in the delivery due to said availability variations are not attributable to the seller, who is not in duty bound to the compensation for damages suffered by the buyer. Reasons of force majeure have also to be considered the accidents (industrial injury, disease, etc) and any other circumstances which may cause a total or partial job reduction, as well as the lack of raw materials, troubles with transportation, etc. The seller reserves the authority to suspend the delivery of the goods if the buyer has not seen to the payment of the invoices relative to other supplies whose terms of payment are overdue. The goods are understood as being delivered for all intents and purposes to the buyer from the time they were picked up by the carrier or the buyer himself at the seller's warehouse.

3. PAYMENT AND TERMS OF PAYMENT

The payments have to be made to the seller's domicile and in accordance with the established conditions. In the event of a delay, the due amounts of money will automatically imply the charge of interests based on the official discount rate plus 5 points. In the event of a non-payment, the buyer is to be considered in default without the necessity of any formal notice by the seller. The presence of possible faults and/or defects in the products does not excuse the buyer for suspending the payment of the invoices. Should the client suspend and/or delay the payments, the seller may suspend the supplies, with the authority to consider the contract automatically terminated by rights and to demand for damages.

4. WARRANTY

CARPANO EQUIPMENT guarantees the products for a period of 24 months starting from the delivery date, for a daily work cycle of 8 hours. The warranty is intended ex works CARPANO EQUIPMENT. CARPANO EQUIPMENT guarantees the performance of its products in accordance with the instructions written in the relative manuals. For the products based on job orders, the warranty is pertaining to the specifics agreed with the client.

5. VOID WARRANTY

In case of any tampering or unauthorized intervention the warranty shall be deemed void.

6. LIABILITY FOR DAMAGE

The seller's liability is limited only to the obligations above and it's expressly agreed that the seller does not accept any liability for damages resulting from any cause connected with the use and utilization of the sold products.

CARPANO EQUIPMENT is not responsible and for no reason whatsoever may the expenses be charged for:

- Machine downtime.
- Direct or in direct damage due to the non-operation of the equipment.
- Working hours spent to solve possible problems on the equipment.

7. RESERVATION OF OWNERSHIP

Until the payment in full of any credit resulting from business relations has taken place, included any additional credit and until the payment of bills and cheques has been made, the property in the goods remains in the seller.

8. COMPETENT COURT

It's established that the court of Bologna will be the sole competent court for every dispute relative to this contract.

9. APPLICABLE LAWS

The applicable law is the Italian law.



CARPANO EQUIPMENT Srl

Via del Legatore, 7 / 40138 Bologna Italy

T. +39 051 6053215 / e-mail: info@carpano.it

carpano.it